

Close-Coupled Mechanical Booster Vacuum Pump Systems

Models

CC4015 CC5430 CC8530 CC1650 CC1685

Features

- Very fast pumpdown for short cycles
- High pumping speed over a wide pressure range
- Single motor and control operates both pumps
- Both pumps start at atmosphere - no pressure switch or bypass manifold required
- Low ultimate pressure capability of 0.2 micron
- Very low vibration characteristics
- Compact, simple assembly with minimum floor area required
- Optional internal mechanical shaft seals for booster, for applications where seconds count in cycle and pumpdown time

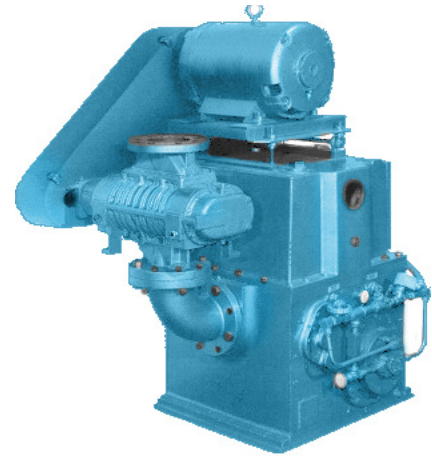

Specifications

SYSTEM MODEL	MAX. CONT. OPERATING PRESSURE* Torr / mbar	MOTOR HP / kW	BLOWER MODEL	BLOWER DISPLACEMENT ACFM / m ³ /h	OIL REQ'D, BLOWER QTS / Liters	COOLING WATER REQ'D @ 60°F GPM / L/min	PUMP MODEL	PUMP DISPLACEMENT ACFM / m ³ /h	OIL REQ'D, BACKING PUMP Gal / Liters
CC4015	60 / 80	10 / 8	MB400	300 / 510	2 / 1.9	2 / 8	KT150	150 / 255	6 / 23
CC5430	105 / 140	15 / 11	MB540	400 / 680	2 / 1.9	2 / 8	KT300	300 / 510	10 / 38
CC8530	10 / 13.3	25 / 19	MB850	625 / 1062	4 / 3.8	4 / 16	KT300	300 / 510	10 / 38
CC1650	50 / 67	40 / 30	MB1600	900 / 1529	4 / 3.8	2.5 / 10	KT500	500 / 850	15 / 57
CC1685	100 / 133	50 / 37	MB1600	1200 / 2039	4 / 3.8	3.5 / 13	KT850	780 / 1325	28 / 106

* CC pumps are designed for continuous operation below tabulated data or for evacuation of inlet system volume which limits pump-down time to approximately 30 minutes. Please review these parameters when sizing the CC series pump.

Typical Pumping Speed Curves

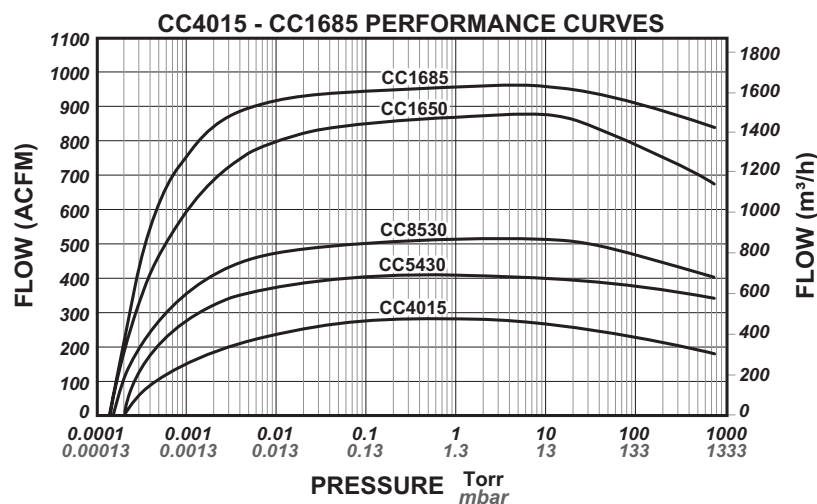

Dimensions

Values shown are approximate and should not be used for construction.

Certified drawings are available through your local Tuthill Vacuum & Blower Systems Sales Professional.

Models CC4015, CC5430, CC8530, CC1650, CC1685

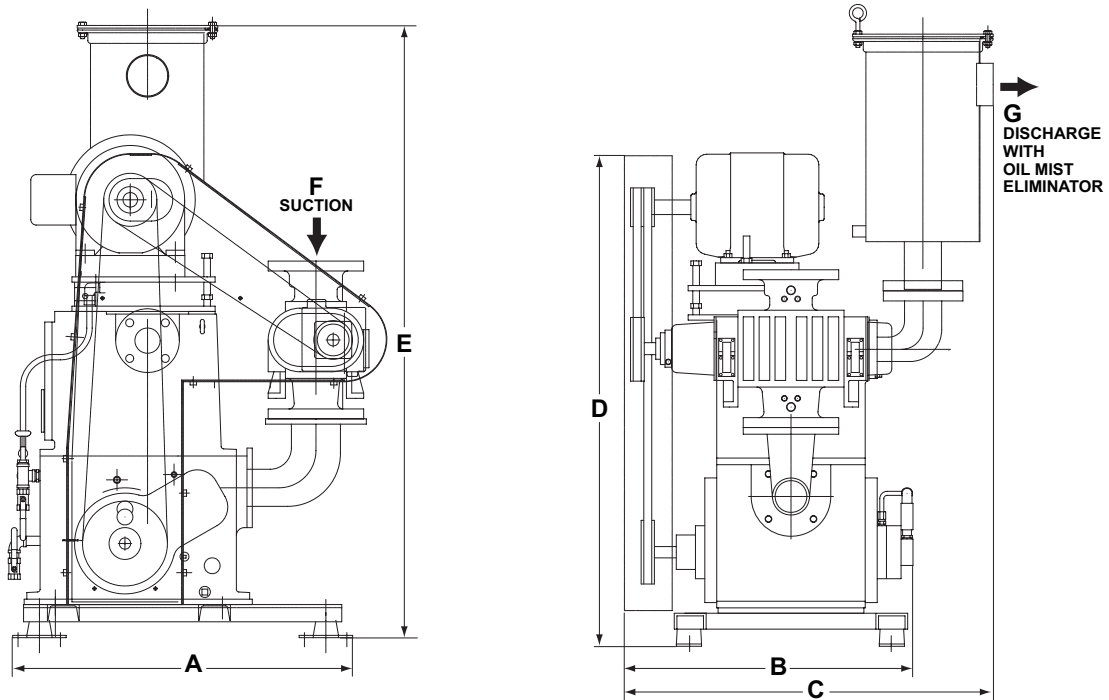

in / mm	A	B	C	D	E	F	G	WEIGHT Lbs / kg
CC4015	32 813	27 686	35 889	47 1194	58 1473	4" FLG	3" NPT	1050 476
CC5430	39 991	35 889	56 1422	57 1448	65 1651	4" FLG	3" NPT	1700 771
CC8530	40 1016	34 864	56 1422	53 1346	64 1626	6" FLG	3" NPT	2050 930
CC1650	52 1321	41 1041	65 1651	75 1905	80 2032	6" FLG	4" FLG	3750 1701
CC1685	54 1372	49 1245	67 1702	77 1956	91 2311	6" FLG	5" FLG	5400 2450

Standard Configuration

- Kinney® KT™ Pump
- Dual Voltage 3/60/230-460V TEFC Motors
- Overtemperature Switch
- Oil mist eliminator
- Steel Base with VibraMounts

Options

- Flexible connectors
- Automatic water control valve to minimize coolant flow
- Oil line filter for backing pump
- Self-contained oil reclamation system
- Special motor and electricals

Your Local Tuthill Vacuum Blower Systems Sales Professional:



Tuthill Vacuum & Blower Systems

4840 West Kearney Street

Springfield, Missouri USA 65803-8702

o 417.865.8715 800.825.6937 f 417.865.2950

tuthillvacuumblower.com



TH-034 01/17